

LOCKING RING

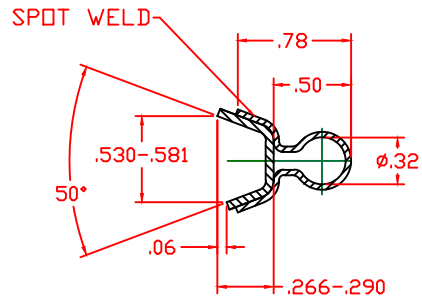

SECTION A-A

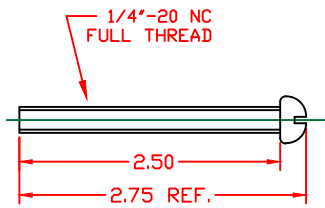
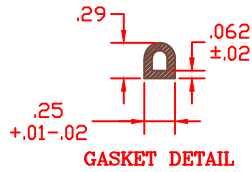

ITEM 1

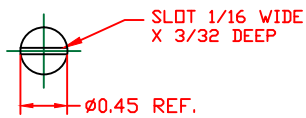

BOLT & NUT

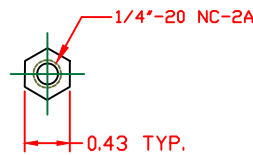

ITEM 2

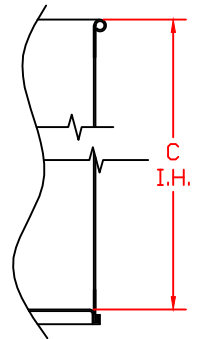

INSIDE HEIGHT DETAIL

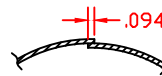
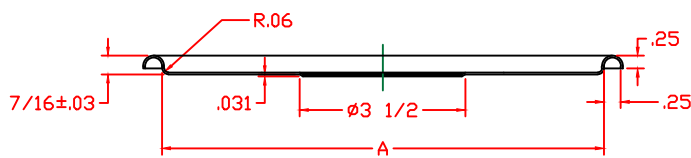

SECTION B-B

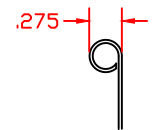

CURL DETAIL

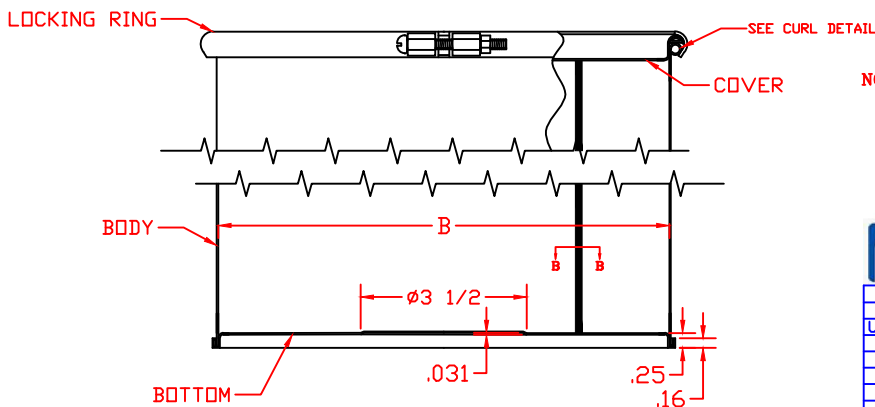

NOTE: NUT AND BOLT FURNISHED WITH ELECTRO-PLATED ZINC PER ASTM B633 TYPE II-YELLOW, SC-2. PLATED ROUND HEAD, .25-20 NC X 2.50 LENGTH, FULL THREAD BOLT WITH SCREWDRIER SLOT 0.06 X 0.09 DEEP WITH NUT

PACKAGING
Specialties Inc.

300 Lake Road
Medina, Ohio 44256
sales@packspec.com
(330) 723-6000, (800) 344-9271
Fax (330) 725-8180

Tolerances	Title	DRUMS, METAL, REUSABLE SHIPPING AND STORAGE
Unless Otherwise Specified	Drawing No.	PSI-MS24347 -
xx Decimals ± .03	Sheet No.	1 OF 3
xxx Decimals ± .005	Date	11/28/2022
Angles ± 2°	Designed By	
	Drawn By	TD
	Checked By	FT
Do not scale this drawing. Dimensions are in inches unless otherwise indicated		